

PRODUCTION

SURFACE PUMPING UNITS

Engineered, manufactured,
and quality controlled by
Weatherford



Weatherford®

STRONGEST OFFERING AND EXPERIENCE

Only from Weatherford.

Known traditionally as the iron workhorse of artificial lift, reciprocating rod lift (RRL) plays an integral role in our offerings. Weatherford precision-engineered surface and subsurface equipment, supported by our pumping unit service, repair, and refurbishment, stands unmatched in the industry. Our integrated approach with highly trained professionals, experienced technical support, and in-depth analysis programs extends traditional performance capabilities of this oldest form of lift.

Total accountability, from design to delivery.

Our international sales and service teams, depth and breadth of product offerings, and extensive global manufacturing capacity are all supported by Weatherford engineering. With our vast product offering and worldwide presence, we will get you the right system tailored to your well conditions, production goals, and budget.

The entire offering of industry-leading pumping units from Weatherford is built on our extensive history of reliability and innovation.

CONTENTS

Advantages and Benefits4	Prime Movers	19
Applications.5	Gas Engines.	19
Equipment5	Weatherford Electric Motors	19
Standard5	Belts	19
Optional5	Sheaves and QD Hubs	19
Maximizer III Pumping Units	6	Optional Components.	20
Features, Advantages, and Benefits6	Direct-Mount Motor Extension	20
Structural Bearings6	High-Mount Motor Extension	20
Parts Identification7	Hanger Bar and Polish Rod Equalizer	20
Dimensional Data with API Dimensions8	Horsehead	21
Specifications	10	Jackshaft Assembly	21
Maximum Effective Counterbalance*	12	Effective Counterbalance Chart	22
Maximizer III Gear Reducers	15	Maximizer and Maximizer II Pumping Units.	22
Parts Identification	16	Maximizer III Pumping Units	22
Maximizer III Components	17	Useful Formulas	23
Crank Pin Assembly	17	Strokes Per Minute (SPM).	23
Crank and Counterbalance	17	Prime Mover Sheave Diameter (d)	23
Center Bearing Assembly.	17	Belt Velocity (v)	23
Equalizer Bearing Assembly	17	Belt Length	23
Pumping Unit Parts and Services.	18	Horsepower of Prime Mover	23
Unmatched Scope.	18	Strokes Per Minute Using a Jackshaft	23
Industry-Leading Service and Repairs.	18	Branch Plants	24
Industry Firsts.	18	Repair Centers	25
Inspection and Preventive Maintenance Service	18	Global Pumping Unit Parts Center	25
Structural Bearings	18	Terms And Conditions Of Sale	26
Gears, Pinions, and Shafts	19	Weatherford Product Warranties	26
Gear Reducer Repair.	19	Customer's Remedies.	26
Portable Concrete Pumping Unit Bases	19		



An optimized RRL system consists of a surface pumping unit powered by an electric or gas prime mover, a rod string, a positive displacement pump, a controller, and software.

Weatherford offers a complete package and full range of reciprocating rod lift (RRL) hardware, electronics, software, and services for all of your application requirements.

Advantages and Benefits

- The wide range of products and the improved equipment performance and longevity result in maximum well production and efficiency.
- In-house engineers provide optimal design and predictives to maximize system performance.
- The comprehensive integrated solution includes rods, pumping units, downhole pumps, prime movers, instruments, controllers, and real-time analysis software for single-source accountability.
- Weatherford provides economical repair and service.
- Positive displacement/strong drawdown maximizes performance.
- Upgraded materials reduce corrosion concerns.
- Production speed is remotely controlled by optimization hardware and software, to adapt to changing well conditions.
- Packaged unit components and global shipment capabilities ease assembly and operation.
- Surface and downhole equipment offer high salvage value.
- Original equipment manufacturer equivalent (OEME) parts, service, and repair are available for all brands of surface pumping units.
- Variable- and fixed-speed advanced controllers are offered for optimal performance.

Applications

- Virtually all applications, including sandy, gaseous, and high viscosity
- Wide range of fluid levels from near surface to seating nipple depth
- Low to medium volume lift capabilities
- All types of wells, including horizontal, slant, directional, and vertical reservoirs
- Industry standard for land and remote applications

Application Considerations	Typical Range	Maximum
Operating true vertical depth (TVD)	100 to 11,000 ft (30.5 to 3,352.8 m)	16,000 ft (4,876.8 m)
Operating volume (BFPD)	5 to 1,500	5,000
Operating temperature	100 to 350°F (37.8 to 176.7°C)	550°F (287.8°C)
Wellbore deviation	0° to 20° landed pump	0° to 90° pump displacement <15°/100 ft build angle
Corrosion handling	Good to excellent	
Gas handling	Fair to good	
Solids handling	Fair to good	
Fluid gravity	>8° American Petroleum Institute (API)	
Servicing	Workover or pulling rig	
Prime mover type	Gas or electric	
Offshore application	Limited	

Equipment

Surface pumping units and reducers represent practical and effective technology at work. This rugged, serviceable equipment is designed to perform reliably under the most adverse conditions. These pumping units are available with a standard T- or wide-frame base, that is skid-mounted for easy relocation. The Sampson posts are a three-legged design; the third leg is removable to facilitate shipping. Walking beams are rated in accordance with the latest API specifications and constructed from a minimum of A36 wide flange steel.

Pumping units come with a complete list of standard equipment. A wide selection of optional items is also available.

Standard

- T-frame base (except Strapjack® unit)
- High-mount package
- Sampson post ladder with ring (not applicable for Strapjack unit)
- Brake assembly
- Crank pin and weight wrenches
- Wireline assembly
- Adjustable motor rails
- Reducer sheave
- Crank guards
- Gear oil
- Belt guard
- Ground level lubrication system

Optional

- Wide-frame base (standard for Strapjack unit)
- Low-mount extension package
- Direct-mount extension package
- Single or dual tiedowns
- Mesh crank guards
- Counterweights
- Concrete base
- Prime mover (electric motor or gas engine)
- Belts and sheave for the prime mover
- Complete software and controller optimization packages
- Caged Sampson post ladder (not applicable for Strapjack unit)
- Jackshaft assembly

Transportation and installation on location will be quoted on request. Complete maintenance packages are available.

PRACTICAL EXPERIENCE, EXCEPTIONAL RESULTS.

Global operators have been putting their trust in Maximizer III™ pumping units in oil fields for more than three decades. The units are recognized worldwide for their dependability, durability, and extended service life. These qualities, plus very high mechanical efficiency, low operating costs, and high resale value, have earned Maximizer III units an excellent reputation.



Maximizer III Pumping Units

Maximizer III pumping units and gear reducers are manufactured in a range of sizes from 114 through 1280 to continually enhance capabilities to address tomorrow's technological challenges. In addition, these facilities hold API licensure. Clients can be confident knowing that each product is designed to exceed the latest API Specification 11E and is backed by the API Specification Q1 Quality Assurance Program.

Features, Advantages, and Benefits

- Maximizer III pumping units are designed with the following features: safety line with stops running the length of the walking beam, lifting hooks, crank guards, belt guards, caged ladders, and ground-level lubrication to provide the highest level of safety.
- The gear reducer is designed with a piece gear case and gears in accordance with API Specification 11E to provide long life and easy maintenance.
- Class I working geometry operates in either direction, which equalizes gear wear and extends reducer life.
- Three-legged Sampson post, with the rear leg mounted high in the pedestal base, adds upper structure stability while equalizing surface loads.
- Crank arm provides convenient counterweight adjustment.
- Bolt-on crank arms can be removed in the field without the use of hydraulic press or special tools.
- Quick-release retainer pin expedites removal of horsehead for well servicing.

Structural Bearings

- Maximizer III high-capacity structural bearings are readily available for ease of maintenance and repair.
- All Maximizer III units have high-efficiency roller bearings.
- Crank pin assemblies feature a standard tapered pin and self-aligning spherical roller bearings, with an easily accessible inspection cover.
- Center bearings have excellent load characteristics and infinite L10 life, with proper maintenance.
- Equalizer bearings for the 114 and 160 units incorporate self-aligning spherical roller bearings. Larger units use a rugged double-tapered roller assembly.

Parts Identification

- 1 Sampson post A-leg
- 2 Main frame
- 3 Reducer sub-base
- 4 Counterweights
- 5 Crank pin assembly
- 6 Crank
- 7 High-mount base extension
- 8 Motor rails
- 9 Brake lever
- 10 Brake assembly
- 11 Gear reducer
- 12 Reducer sheave
- 13 Pitman arm
- 14 Sampson post support leg
- 15 Center bearing assembly
- 16 Equalizer beam
- 17 Equalizer bearing assembly
- 18 Sampson post ladder
- 19 Walking beam
- 20 Horsehead
- 21 Wireline
- 22 Polish rod hanger

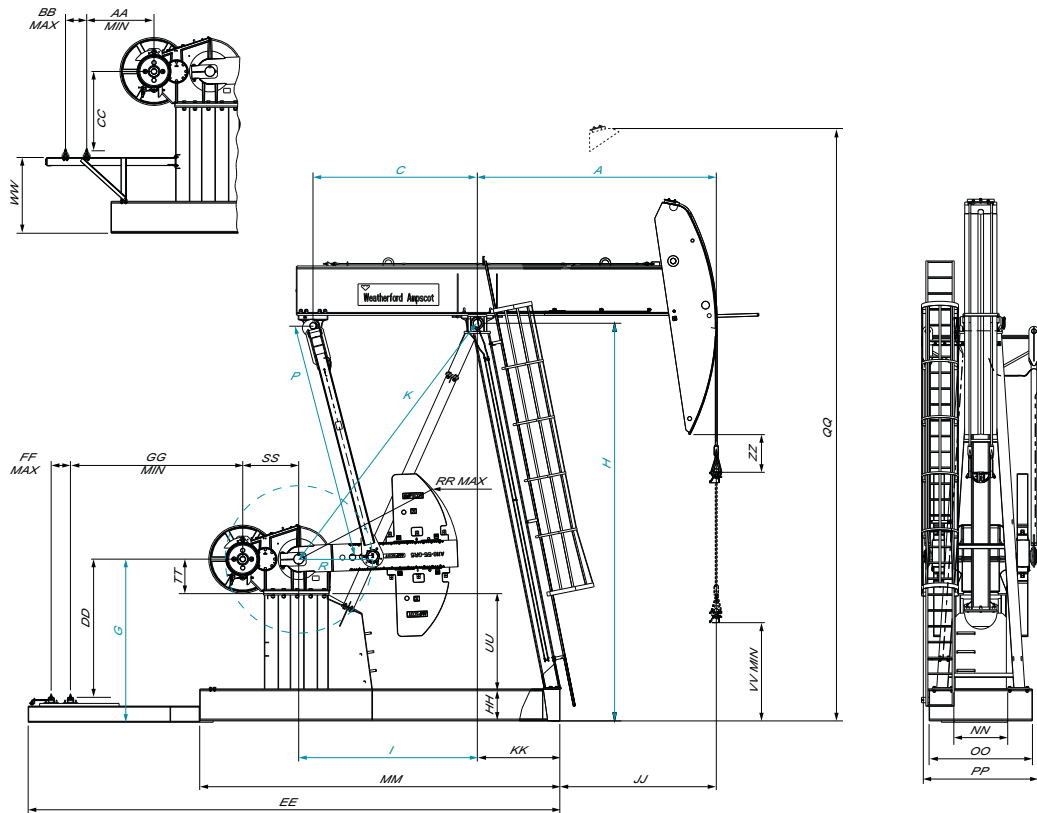
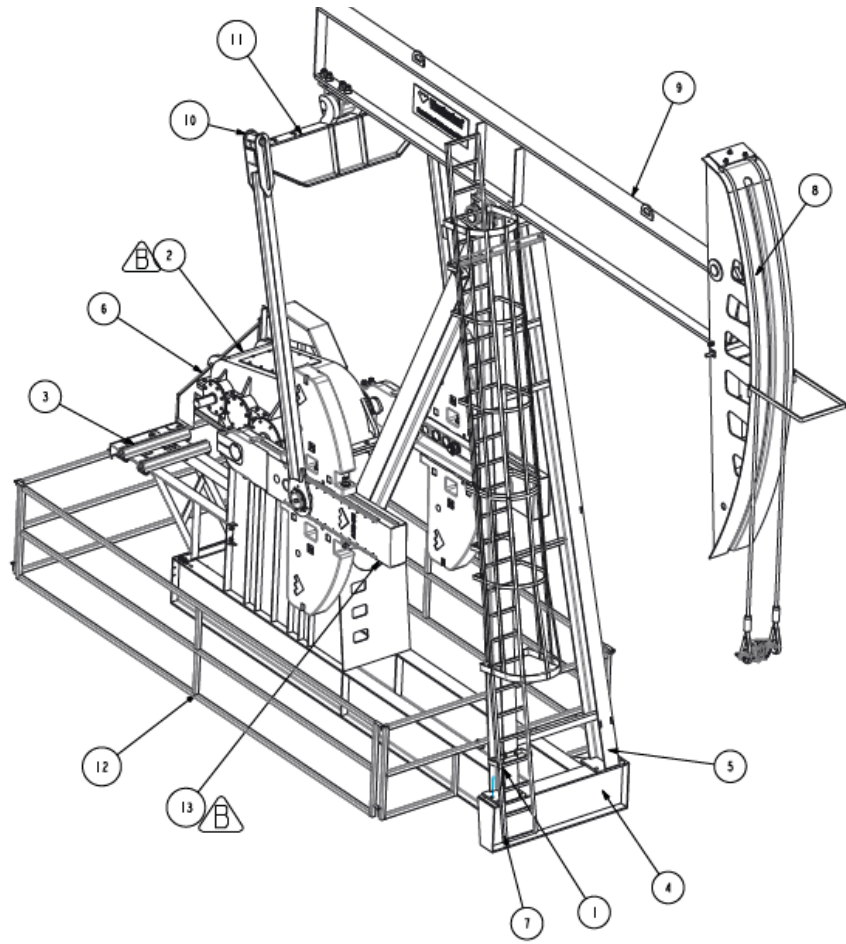

Dimensional Data with API Dimensions

GRP	Size	API Dimensional Data (in.)													
		A	C	G	H	I	K	P	R	AA MIN	BBMAX	CC	DD	EE	FF MAX
2A	114-173-74	84	85	82	179 3/8	94	135 2/8	102 6/8	36	28	26	50 1/8	NA	221	NA
2A	114-119-86	94	83	82	179 3/8	94	135 2/8	102 6/8	36	28	26	50 1/8	NA	221	NA
2A	114-119-100	110.63	83	82	179 3/8	94	135 2/8	102 6/8	36	28	26	50 3/8		221 4/8	
2A	160-173-100	110.63	83	82	179 3/8	94	135 2/8	102 6/8	36	27	25	50 1/8	NA	235	NA
2A	160-173/200-74	84	84 6/8	81.88	179	94	135 3/8	102 6/8	36	27	25	50 2/8		225 1/8	
3	228-246-86	97.63	118	103 1/8	243 3/8	125.63	188 2/8	142.63	50	67 6/8	14	50 4/8	84.63	370 3/8	41
2	228-213-100	112	84	82	179 2/8	90	132.63	99 6/8	36	56	14	29 3/8		247 3/8	
3	228-213-120	135 4/8	118	103 1/8	243 3/8	125.63	188 2/8	142.63	50	40 3/8	14	50 4/8		296 3/8	
3	320-305-100	118	118	103 4/8	243 6/8	126 4/8	188.88	142.63	50	37 1/8	18	50 4/8	84.88	370 3/8	29
3	320-305-120	136	118	103	243 2/8	126.63	188.88	142.63	50	37 1/8	18	50 4/8		301 2/8	
4	320-256-144	156 1/8	113.63	104 6/8	243 2/8	126.63	188.88	142.63	50	24	18	50 4/8		301 2/8	
4	456-256/305-144	155 2/8	124	122 6/8	274 3/8	133	201 6/8	148	55	54 6/8	18	62 3/8	104 3/8	312.63	18
4	640-305-144	155 3/8	124	122 6/8	274 3/8	133	201 6/8	148	55	34.63	18	62 3/8		318 1/8	
5	640-365-168	177 6/8	122	119.88	295 1/8	132	220	176.88	55	34.63	18	59 4/8		321 4/8	
5	912-365-168	177 6/8	122	119.88	295 1/8	132	220	176.88	55	32.63	20	59 4/8		321 4/8	
5	912-427-168	177 6/8	122	119.88	295 1/8	132	219 3/8	176.88	55	32.63	20	59 4/8		321 4/8	
5	912-427-192	203 1/8	122	119.88	295 1/8	132	219 3/8	176.88	55	32.63	20	59 4/8		321 4/8	
6	1280-305-240	230	122	120 1/8	339 6/8	133 3/8	257	219.88	60	27 6/8	20	59 6/8		329 6/8	
6	1280-365-192	203	122	120 1/8	339 6/8	133 3/8	257	219.88	55	27 2/8	20	59 6/8		329 6/8	
6	1280-365-240	230	122	120 1/8	339 6/8	133 3/8	257	219.88	60	27 6/8	20	59 6/8		329 6/8	
6	1280-427-192	203	122	120 1/8	339 6/8	133 3/8	257	219.88	55	27 2/8	20	59 6/8		329 6/8	
6	1824-365-240	230	122	120 1/8	339 6/8	133 3/8	254 4/8	219.88	60	16 2/8	23	62 6/8		329.88	

Dimensional Data (in.)

GG MIN	HH	JJ	KK	MM	NN	OO	PP	QQ	RR MAX	SS	TT	UU	VV MIN	WW	ZZ
NA	15.88	42 4/8	41 4/8	180	28	72 1/8	70.63	249 3/8	80	24.63	17 1/8	49	71 4/8	27.88	25
NA	15.88	52.63	41 4/8	180	28	72 1/8	70.63	259 6/8	80	24.63	17 1/8	49	70 6/8	27.88	15
	15 6/8	68 6/8	41.88	181	28	72 1/8	70.63	273.88	80	24.63	17 1/8	49	65 4/8	27 6/8	14 2/8
NA	15.88	69	41 4/8	180	28	72 1/8	68.88	274 6/8	80	30 2/8	20	46 1/8	64.63	27.88	14.06
	15 6/8	42 4/8	41 4/8	179.63	28	72 1/8	68.88	249 3/8	80	30 2/8	20	46 1/8	72 3/8	27 6/8	23.88
99 1/8	15.88	44 2/8	53 2/8	246 6/8	36	90 4/8	76 6/8	322 6/8	100 3/8	33 2/8	24	63 2/8	75 2/8	48 3/8	76.88
	15.88	70 4/8	41 4/8	180	36	72 1/8	76 6/8	270 2/8	80 3/8	33 3/8	24	42 1/8	53 1/8	48 3/8	15 4/8
	15.88	81 6/8	53 3/8	246 6/8	36	72 1/8	76 6/8	346 3/8	100	33 2/8	24	63 2/8	89 6/8	48 3/8	29.88
102	16 2/8	64.63	53 2/8	246.88	36	72 1/8	84	337 1/8	100	35.63	24	63 2/8	72 4/8	48 6/8	48.63
	15 6/8	82 3/8	53 6/8	247 3/8	36	72 1/8	84	350 6/8	100	35.63	24	63 2/8	84 4/8	48 2/8	29.88
	15 6/8	102 3/8	50.88	247 3/8	36	72 1/8	84	375	100	35.63	24	63 2/8	67.63	48 2/8	15 4/8
108 6/8	23.63	94	61 2/8	267 3/8	38 3/8	76 6/8	85 4/8	410 4/8	118 2/8	39.88	28	71 1/8	99 2/8	56 1/8	21 4/8
	23.63	94 2/8	61 2/8	267 3/8	38 3/8	76 6/8	99 1/8	410 3/8	118 4/8	45 6/8	30	69 1/8	98 6/8	56 2/8	21
	23.63	116.63	61 2/8	267 3/8	38 3/8	76 6/8	99 1/8	442 6/8	118 4/8	45 6/8	30	66 2/8	75 1/8	56 2/8	40 4/8
	23.63	116.63	61 2/8	267 3/8	38 3/8	76 6/8	103 4/8	442 6/8	118 4/8	45 6/8	30	66 2/8	75 1/8	56 2/8	40 4/8
	23.63	116.63	61 2/8	267 3/8	38 3/8	76 6/8	103 4/8	442 6/8	118 4/8	45 6/8	30	66 2/8	75 1/8	56 2/8	40 4/8
	23.63	141.88	61 2/8	267 3/8	38 3/8	76 6/8	103 4/8	463	118 4/8	45 6/8	30	66 2/8	76 2/8	56 2/8	11
	23.63	161	68	308.88	49 4/8	76 3/8	117 1/8	546 4/8	118	52 4/8	33	63 4/8	83 6/8	56	17 4/8
	23.63	135	68	308.88	49 4/8	76 6/8	117 1/8	509.88	118	52 4/8	33	63 4/8	131 3/8	56	23 6/8
	23.63	161	68	308.88	49 4/8	76 3/8	117 1/8	546 4/8	118	52 4/8	33	63 4/8	83 6/8	56	17 4/8
	23.63	135	68	308.88	49 4/8	76 6/8	117 1/8	509.88	118	52 4/8	33	63 4/8	131 3/8	56	23 6/8
	23.63	161	68	308.88	49 4/8	76 3/8	131	546 4/8	118	58 6/8	36	63 4/8	83 6/8	56	17 4/8

Specifications

API Size	Maximum Polished Rod Capacity (lb)	Standard Strokes-Fourth Stroke Optional (in.)	Torque Factor at 90°-Fourth Stroke Optional (in.)	Wireline Size (in.)	Wireline Center (in.)
114-143-074	14,300	74, 63, 52	36, 31, 26	1.00 × 274.00	11.00
114-119-086	11,900	86, 73, 61	41, 35, 30	1.00 × 274.00	11.00
114-119-100	11,900	100, 85, 71	48, 42, 35		
160-200-074	20,000	74, 63, 52	36, 31, 26	1.00 × 274.00	11.00
160-173-100	17,300	100, 85, 71	48, 42, 35	1.00 × 300.00	11.00
228-246-086	24,600	86, 77, 68	41, 37, 33	1.13 × 360.00	12.00
228-213-100	21,300	100, 85, 71	48, 41, 35	1.00 × 300.00	11.00
228-213-120	21,300	120, 107, 94	57, 51, 46	1.13 × 360.00	12.00
320-305-100	30,500	104, 93, 82	49, 45, 40	1.13 × 360.00	12.00
320-256-120	25,600	120, 107, 94, 82	57, 52, 46	1.13 × 360.00	12.00
320-305-120	30,500	120, 107, 94, 82	57, 52, 46, 45	1.13 × 360.00	12.00
320-256-144	25,600	144, 128, 113, 98	68, 61, 55	1.13 × 384	12.00
456-305-144	30,500	146, 124, 103, 83	67, 58, 49	1.25 × 420.00	16.00
640-305-144	30,500	146, 124, 103, 84	67, 58, 50		
640-365-168	36,500	168, 143, 119, 96	80, 69, 58	1.38 × 480	16.00
912-365-168	36,500	168, 143, 119, 96	80, 69, 58	1.38 × 480	16.00
640-365-168	36,500	168, 143, 119, 96	80, 69, 58	1.38 × 480	16.00
912-365-168	36,500	168, 143, 119, 96	80, 69, 58	1.38 × 480	16.00
1280-365-192	36,500	192, 163, 136, 110	91, 79, 66	1.38 × 480	16.00
1280-427-192	42,700	192, 163, 136, 110	91, 79, 66		
1280-305-240	30,500	239, 206, 175	112, 98, 85	1.38 × 584	16.00
1280-365-240	36,500	239, 206, 175	112, 98, 85		
1824-305-240	36,500	239, 206, 175	112, 98, 85	1.38 × 584	16.00



Maximum Effective Counterbalance*

Calculate ECB for other crank arm positions using the Effective Counterbalance Chart.

When selecting counterweights, the value in the table must be equal to or greater than the required counterbalance.

API Size	Structural Imbalance	Crank Number	Crank Only	4-B	4-D	4-F	4-H	4-J	4-L
114-143-074	347	A80L-36	3610	6710	7800	8880	9860	11100	
			4130	7720	8980	10240	11360	12810	
			4850	9130	10640	12130	13480		
114-119-086	125	A80L-36	2970	5670	6620	7560	8410	9500	
			3420	6550	7650	8750	9730	10990	
			4060	7790	9100	10410	11580		
114-119-100	-127	A80L-36	2290	4580	5390	6190	6910	7830	8570
			2670	5330	6270	7200	8030	9100	9960
			3210	6390	7500	8610	9610	10880	11900
160-200-074	340	A80L-36	3590	6680	7770	8850	9820	11060	12050
			4110	7690	8950	10200	11320	12760	13910
			4830	9100	10600	12090	13430	15140	16510
160-173-100	-132	A80L-36	2280	4580	5390	6190	6910	7830	8570
			2670	5330	6270	7190	8030	9100	9950
			3210	6380	7500	8610	9600	10880	11900
228-246-086	1530	A100-50	8010	11500	12750	14020	15170	16630	17820
			8690	12560	13940	15340	16620	18240	19560
			9570	13900	15450	17020	18450	20270	21750
228-213-100	176	A80-36	3240	5570	6390	7200	7930	8870	9620
			3710	6400	7350	8290	9130	10210	11080
			4380	7580	8700	9820	10820	12110	13130
228-213-120	400	A100-50	5060	7580	8480	9390	10220	11270	12130
			5560	8340	9340	10350	11270	12430	13380
			6190	9310	10420	11560	12590	13890	14960
320-305-100	1188	A100-50	6530	9420	10450	11500	12450	13660	14640
			7110	10300	11440	12600	13650	14990	16080
			7830	11410	12690	13990	15170	16670	17890
320-256-120	669	A100-50	5310	7810	8700	9610	10440	11490	12340
			5800	8570	9560	10570	11480	12640	13590
			6430	9530	10640	11770	12800	14100	15160
320-305-120	669	A100-50	5310	7810	8700	9610	10440	11490	12340
			5810	8570	9560	10570	11480	12640	13590
			6430	9530	10640	11770	12800	14100	15160
320-256-144	-100	A100-50	3760	5850	6590	7350	8040	8910	9620
			4180	6490	7320	8160	8920	9890	10670
			4710	7300	8230	9170	10030	11120	12000

4-N	4-P	4-R	4-S	4-X	4-Y	4-Z	4-ZJ
13930	14940						
16090	17260						
19110							
9960	10680	12380					
11570	12400	14380					
13830	14820	17170					
20130	21290	23960					
22110	23390						
24610							
11030	11760	13490	17420				
12710	13550	15550	20090				
15080	16080	18450					
13790	14630	16550	20960				
15220	16140	18270					
17020	18050	20450					
16550	17500	19710	24770				
18180	19240	21690	27280				
20250	21440	24180	30460				
13990	14820	16740	21120				
15410	16330	18450	23300				
17210	18240	20620					
13990	14820	16740	21120	23320	27230		
15410	16330	18450	23300	25730	30060		
17210	18240	20620	26060	28780			
11000	11690	13290	16940	18770	22030		
12200	12970	14730	18780	20810	24420		
13710	14570	16560	21110	23380			

Maximum Effective Counterbalance* (continued)

Calculate ECB for other crank arm positions using the Effective Counterbalance Chart.

When selecting counterweights, the value in the table must be equal to or greater than the required counterbalance.

API Size	Structural Imbalance	Crank Number	Crank Only	4-B	4-D	4-F	4-H	4-J	4-L	4-N	4-P	4-R	4-S
456-305-144	-80	A118-55	7510	10070	10990	11940	12810	13900	14800	16560	17440	19430	24000
			8640	11580	12630	13720	14720	15980	17010	19040	20040	22330	27580
			10220	13680	14930	16220	17400	18880	20100	22490	23680	26380	
640-305-144	-80	A118-55	7510			11930	12790	13890	14790	16550	17420	19410	23980
			8640			13710	14710	15960	17000	19020	20030	22310	27560
			10220			16210	17380	18860	20090	22470	23660	26360	
640-365-168	-434	A118-55	5910				10460	11390	12150	13640	14380	16070	19930
			6890				12130	13200	14080	15790	16650	18590	23050
			8260				14450	15710	16750	18790	19800	22100	27380
912-365-168	-434	A118-55	5910				10460	11390	12150	13640	14380	16070	19930
			6890				12130	13200	14080	15790	16650	18590	23050
			8260				14450	15710	16750	18790	19800	22100	27380
912-427-168	-921	A118-55	5500				9980	10900	11670	13150	13900	15580	19450
			6480				11650	12710	13590	15310	16160	18110	22560
			7850				13960	15220	16270	18300	19310	21610	26890
912-427-192	-1434	A118-55	4710					8920	9580	10890	11540	13010	16400
			5580					10500	11270	12770	13520	15220	19120
			6240					12700	13610	15390	16280	18290	22910
1280-365-192	-1123	A118-55	6790					9210	9880	11180	11830	13300	16680
			2500					10810	11580	13080	13830	15530	19440
			3350					13020	13940	15720	16610	18620	23250
1280-427-192	-1723	A118-55	3890					8610	9280	10580	11230	12700	16080
			4760					10200	10980	12480	13230	14930	18830
			5960					12420	13330	15110	16000	18010	22640
1280-305-240	-2900	A118-60	1860					5690	6230	7290	7820	9010	11750
			2500					6860	7470	8680	9270	10640	13760
			3350					8420	9140	10540	11240	12820	16450
1280-365-240	-2688	A118-60	5870					9700	10240	11290	11820	13010	15750
			7060					11420	12030	13230	13830	15190	18310
			8650					13730	14440	15830	16540	18110	21750
1824-365-240	-2688	A118-60	1862					5690	6230	7290	7820	9010	11750
			2502					6850	7460	8670	9270	10640	13760
			3352					8410	9130	10530	11240	12820	16450

Maximizer III Gear Reduces

4-X	4-Y	4-Z	4-ZJ
21990	25600	31120	
25410	29590	35950	
30180	35120		
21990	25600	31120	
25410	29590	35950	
30180	35120		
21500	25120	30640	
24930	29100	35460	
29690	34630	42170	
18190	21360	26190	29830
21190	24850	30420	34610
25360	29690	36290	41250
18470	21640	26460	
21510	25160	30730	
25700	30030		
17870	21040	25860	29490
20900	24560	30120	34310
25090	29430	36030	40990
13200	15770	19680	22630
15410	18330	22790	26150
18380	21780	26970	
17210	19770	23690	26630
19970	22880	27350	30700
23680	27080	32270	
13200	15770	19680	
15410	18330	22790	
18380	21780	26970	

Model Size	Torque Rating (in.-lb)	Gear Ratio	Crank Shaft Diameter Maximizer II (in.)	Sheave Bore Diameter (in.)	Sheave Size Belt Section/Pitch Diameter (in.)	Oil Capacity (gal)
1824	1,824,000	28.333:1	9.00	5.50	120/58	173
1280	1,280,000	28.05:1	9.25	5.00	10C/50	141
912	912,000	31.49:1	7.75	4.25	8C/50	121
640	640,000	31.49:1	7.75	4.25	6C/50	111
456	456,000	28.396:1	7.75	3.62	5C/50	80
320	320,000	30.72:1	7.75	3.50	4C/44	48
228	228,000	30.227:1	6.00	3.13	3C/36	43
160	160,000	29.21:1	6.00	2.94	3C/36	22
114	114,000	29.2837:1	5.50	2.25	3C/33	16

Parts Identification

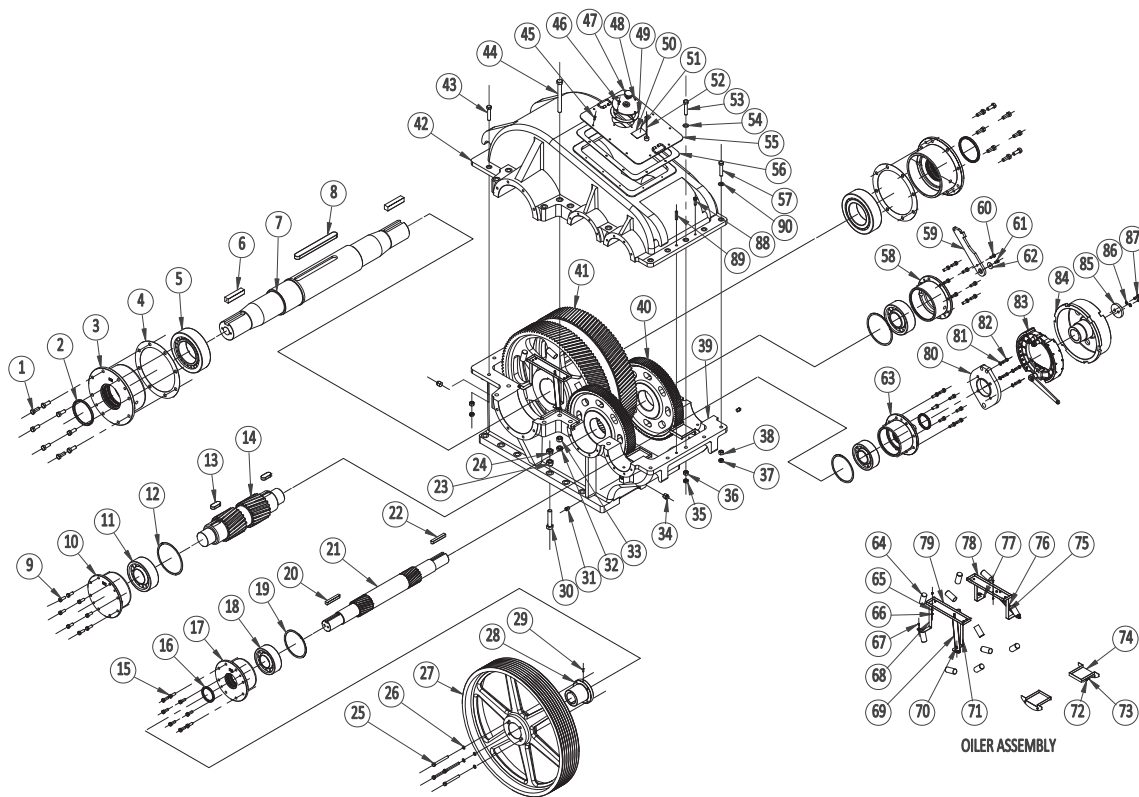

- | | | |
|-------------------------|--|-------------------------------------|
| 1 Gearbox | 20 Inspection cover gasket | 39 Intermediate-speed support plate |
| 2 Low-speed shaft | 21 Splash guard | 40 Brake snap ring |
| 3 Low-speed gear | 22 Splash guard bolt | 41 Brake band |
| 4 Low-speed pinion | 23 Low-speed bolt | 42 Brake wheel |
| 5 High-speed gear | 24 Low-speed housing | 43 High-speed support plate |
| 6 High-speed pinion | 25 V-ring | 44 High-speed seal |
| 7 Oiler assembly | 26 Low-speed shim | 45 High-speed housing |
| 8 Hose | 27 Low-speed slinger | 46 High-speed gasket |
| 9 Oiler assembly nut | 28 Low-speed bearing | 47 High-speed bearing |
| 10 Flat washer | 29 Crank key | 48 High-speed snap ring |
| 11 Bolt | 30 Low-speed gear key | 49 High-speed slinger |
| 12 Polyethylene gasket | 31 High-speed gear key | 50 Brake key |
| 13 Gearbox cover gasket | 32 Intermediate-speed snap ring | 51 Sheave key |
| 14 Gearbox cover | 33 Intermediate-speed bearing | 52 High-speed housing bolt |
| 15 Gearbox cover bolt | 34 Intermediate-speed gasket | 53 Bushing |
| 16 Lock washer | 35 Intermediate-speed housing | 54 Reducer sheave |
| 17 Flat washer | 36 Intermediate-speed housing bolt | 55 Cap screw |
| 18 Breather | 37 Intermediate-speed support plate bolt | 56 Lock washer |
| 19 Inspection cover | 38 High-speed support plate bolt | |

Maximizer III Components

Crank Pin Assembly

- 1 Crank pin nut
- 2 Cotter pin
- 3 Crank pin
- 4 Relief fitting
- 5 Crank pin housing
- 6 Seal
- 7 Bearing
- 8 Snap ring
- 9 Crank pin housing cap
- 10 Housing cap bolt
- 11 Grease fitting

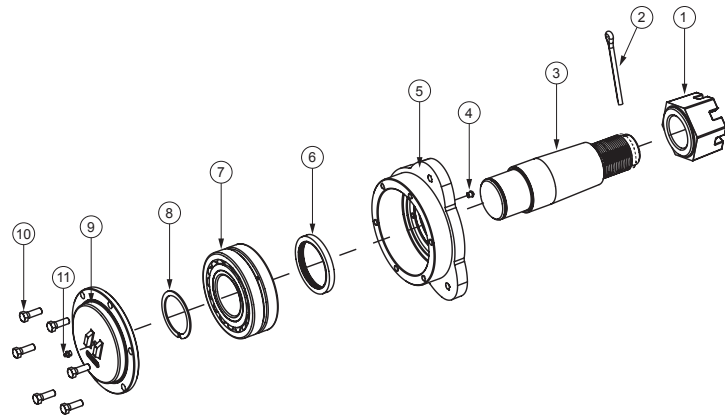

Crank and Counterbalance

- 1 Crank
- 2 Counterweight
- 3 Washer
- 4 Nut
- 5 Counterweight bolt
- 6 Weight adjusting crank
- 7 Nut
- 8 Lock washer
- 9 Flat washer
- 10 Bolt

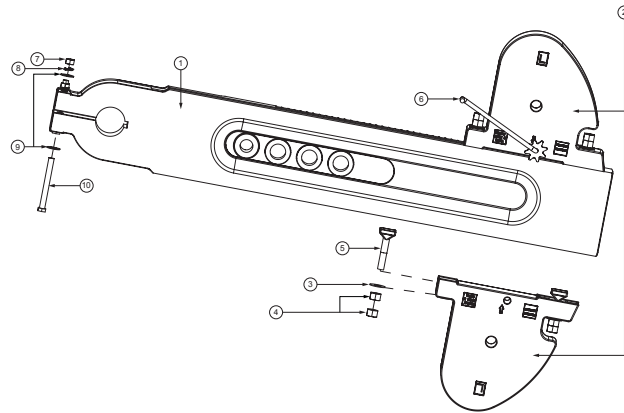

Center Bearing Assembly

- 1 Saddle trunnion
- 2 Bearing retainer ring
- 3 Bearing
- 4 Saddle shaft
- 5 Bearing adapter
- 6 Saddle trunnion cap
- 7 Bolt

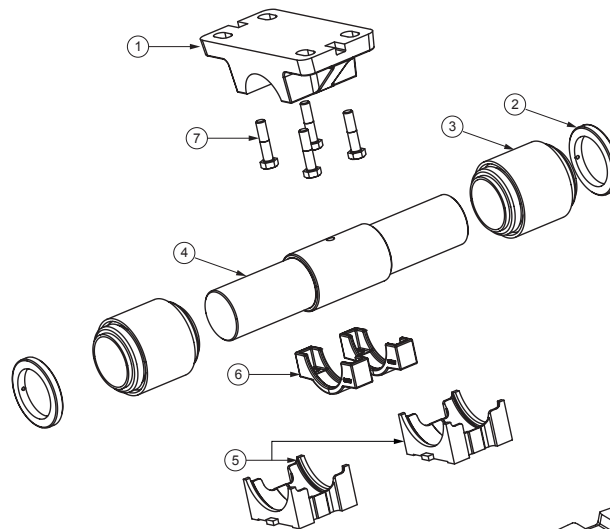

Equalizer Bearing Assembly

- 1 Grease nipple
- 2 Bearing retaining ring
- 3 Bolt
- 4 Bearing housing
- 5 Bearing
- 6 Equalizer shaft

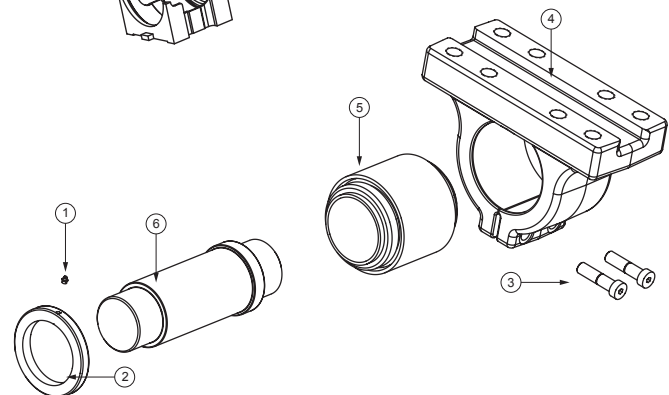

Pumping Unit Parts and Services

Unmatched Scope

- Only company with expertise in all forms of artificial lift
- Global footprint from which to stage equipment

Industry-Leading Service and Repairs

- Comprehensive servicing of all industry brands manufactured in the last century
- Experienced technicians that provide service wherever your well is located

Industry Firsts

- Specialization of infield moving and installation of pumping units
- Complete repair of all sizes and brands of pumping units
- Manufacture and installation of a self-lubricating, maintenance-free polytetrafluoroethylene (PTFE) pumping unit structural bearings
- Manufacture of steel-reinforced portable concrete pumping unit bases
- Manufacture and installation of OEM and OEME exchange structural bearings
- Manufacture of a complete line of replacement, API-licensed pumping unit gears, pinions, and shafts
- Complete crater repair service from disassembly to installation
- In-shop and in-field gear reducer repair service
- Specially trained crews for infield pumping unit repairs
- Full line of gas and electric prime movers
- Operation of a fleet of custom-designed field service cranes equipped with specialized tooling
- Rigorous, documented inspection and maintenance programs
- Cold-process structural member straightening and repair
- Customer-dedicated account representatives Redesign and retrofitting services
- Gear reducer assembly and repair
- Hotshot service to facilitate repairs
- On-site crank boring and sleeve installation
- Warrantied products and services

Weatherford pumping unit services have provided the most comprehensive servicing of all industry brands and OEM units manufactured in the last century:

- Inspection and maintenance programs
- Pumping unit inspection
- Complete pumping unit repair
- Pumping unit installation
- Turnkey pumping unit setting
- Bearing remanufacture using PTFE and manufacturer-style bearings
- Engineering and application assistance
- Cold-process structural member straightening and repair
- Gearbox assembly and repair
- Hotshot service to facilitate repairs
- OEME bearing assemblies
- Crank boring in the field
- Full line of gas and electric prime movers

Weatherford trucks and cranes are designed and rigged for complete turnkey optimization of your installation. Dispatched by radio and cell phone, our crews arrive at locations ready and fully trained to diagnose, quickly service, and perform needed repairs.

Weatherford has manufacturing facilities strategically located near major producing areas, and our plants are equipped to run 24 hours per day if needed. Our pumping unit services group provides efficient and cost-effective repairs.

Inspection and Preventive Maintenance Service

Using field inspection techniques developed and refined during 50+ years of experience and enhanced with custom engineered inspection vehicles, our trained operators provide a detailed inspection of the pumping unit and all its components. Recognizing the effects of wear or other issues before a problem develops saves time and money. Our team prepares a written report and reviews it with you to determine needed repairs or maintenance. Bearing lubrication and tightening of all bolts are included in this service.

Structural Bearings

Weatherford has the world's largest inventory of bearing assemblies for oil field pumping units. Our inventory includes the most frequently used structural bearing assemblies from all major pumping unit manufacturers. Parts for obsolete units are also available. Failed bearing assemblies can be exchanged for rebuilt assemblies by our specially rigged service trucks and cranes in a single trip to the location, which reduces expensive downtime and lost production time.

Weatherford manufactures OEM and OEME pumping unit bearings in complete assemblies along with components and finished housings for the most frequently used structural bearing assemblies.

Developed in 1963, the Weatherford self-lubricated, long-life bearing for oil well pumping units significantly reduces field maintenance requirements. The sleeve-type bearing is made with a proprietary stabilized PTFE, a unique composite material that provides strength, weather resistance, self-lubrication, and long life. The bearing resists chemical degradation, blow-sand, and severe cold. Several hundred thousand bearings in use around the world have demonstrated its performance.

Gears, Pinions, and Shafts

Weatherford OEM and OEME gears, pinions, and shafts are designed to exceed API Specification 11E and backed by Q1 quality assurance program. Herringbone, double helical, and helical gears, pinions, and shafts made by Weatherford have earned a solid reputation as the industry's most reliable, cost effective replacement gearing. Our extensive inventory of gearbox components assures prompt delivery of a smoothly operating, repaired gear reducer for a fraction of the cost of a new one. All Weatherford gears are thoroughly inspected for precision and quality.

Weatherford can provide gears in a variety of sizes for pumping units from most original manufacturers. We offer quick turnaround, quality service, and an affordable price for equipment no longer supported by the original manufacturer. We also offer custom replacement, including evaluation of failure, design, materials, and engineering solutions.

Gear Reducer Repair

Weatherford Pumping Unit Services, staffed with trained crews and specially rigged equipment developed since 1957, offers full turnkey repair of pumping unit gear reducers from disassembly in the field, to the shop, and back to the field quickly and efficiently. manner. Minor repairs such as replacing high speed pinions and bearings can be done in the field.

With 300- to 600-ton horizontal wheel presses located at strategic repair facilities, Weatherford Pumping Unit Services is fully equipped to furnish gears, pinions, and shafts along with labor to fully recondition the largest gear reducers. Repaired reducers are performance tested at Weatherford facilities to ensure oiling function and smooth, trouble-free operation before delivery for installation by our trained crews. Cratered or bad reducers can be picked up, delivered to a Weatherford repair shop, rebuilt, and put back in service quickly. In some cases a fully repaired reducer of the same make and size can be offered as an exchange to get the unit back in service in one day.

If the reducer is not repairable, requires obsolete parts, is of foreign make, or OEM gears are not available, a Weatherford or other brand reducer can be retrofitted to the pumping unit.

Weatherford reducer repairs include replacement of roller bearings, repair and replacement of the oiling system, and high-speed oilers for units that will not lubricate bearings at lower SPM. Brake repairs use OEM and OEME parts or retrofit Weatherford brake assemblies when obsolete brake parts are no longer available. Flush and oil change service is included.

Portable Concrete Pumping Unit Bases

Innovated and patented in 1957, Weatherford pre-stressed portable concrete bases are available and in stock for any pumping unit size or manufacturer. The bases are reinforced at points of greatest stress.

Prime Movers

Weatherford offers a full line of rugged, dependable gas and electric prime movers for all makes and models of pumping units. We also offer parts such as oil bath jack shafts, belts, sheaves, and QD hubs for all units and prime movers.

Gas Engines

Weatherford is a master distributor of new engines and parts for Arrow, Ford, GM, and Cummins. When they are available, we also provide rebuilt gas engines by Ajax, Arrow, Ford, Waukesha, and others.

- Engine rebuilding
- Cylinder head rebuilding and repair
- Engine machine shop services
- New engine sales and service
- Engine technical support
- Product training
- Parts department
- Emission equipment sales
- Emission testing and system installations

Weatherford Electric Motors

Weatherford has an extensive inventory of electric motors in various sizes, horsepower, and designs for most typical applications. Additionally, special designs and frames can be in inventory or available with a short lead time:

- Nema D for the dynamic loads of pumping units
- Nema B for steady-state loads, such as pumps
- Inverter-rated motors for use with a variable-frequency drive
- Special frame-construction motors for hazardous locations

Belts

Belts are available in single and power band in B, C, and D groove.

Sheaves and QD Hubs

We have available all sizes of sheaves in B, C, and D groove. We also have QD hubs for all models of units and prime movers.

Optional Components

Direct-Mount Motor Extension

For applications where a concrete base is being used, we recommend using direct-mount rails to reduce engine vibration. A separate low-mount extension base with adjustable rails is also available for order. Either of these setups will accommodate gas or electric motors.

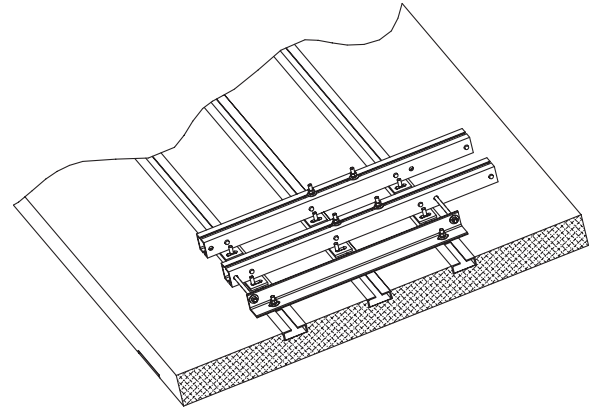

High-Mount Motor Extension

A high-mount extension is advisable if the pumping unit will be powered by an electric motor. This economical mount helps protect the electric motor from blowing snow and dust that reduce motor life. High-mount motor extensions are assembled with zinc plated adjusting rods for easy belt adjustment. Fully enclosed or swing-away belt guards are available at the time of order.

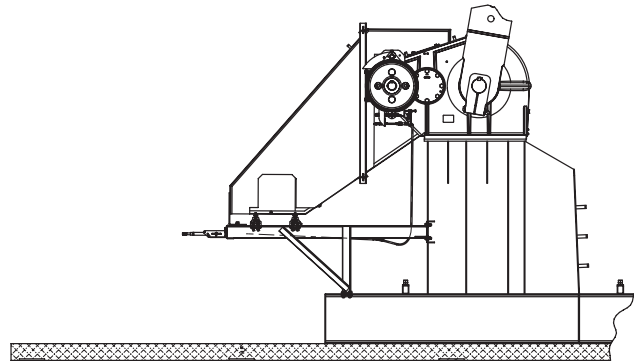

Hanger Bar and Polish Rod Equalizer

Ductile iron hanger bars come complete with ends for easy wireline replacement and adjustment. Machined surfaces provide positive contact between the hanger bar and the polish rod clamp. The use of a sliding gate allows field personnel to detach the polish rod with ease.

The polish rod equalizer is designed to continually adjust for any rod misalignment between the hanger bar, polish rod clamp, or rod rotator. A reduction in bending stresses significantly extends the life of the polish rod and reduces wear on the stuffing box and related equipment. The polish rod equalizer can be ordered to fit 1 1/4- or 1 1/2-in. polish rods and only takes a few minutes to install. The system requires no maintenance or lubrication.

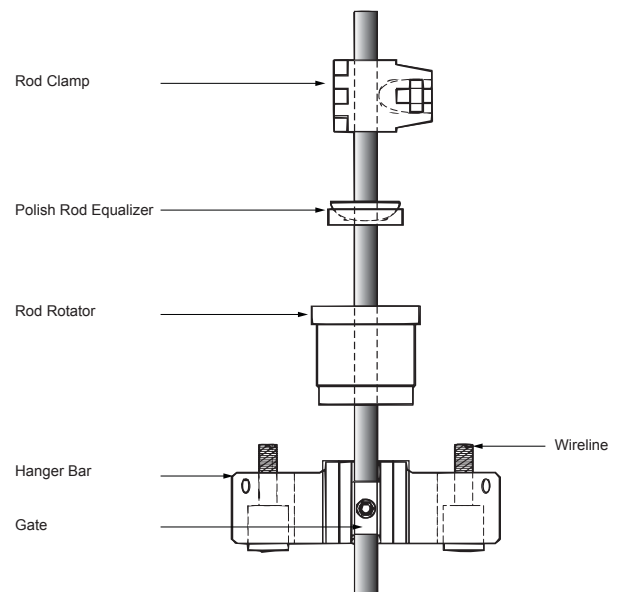

Horsehead

The horsehead has been designed for easy removal and has ample clearance for well servicing. Adjusting screws on both the horsehead and the saddle trunnion permit lateral and longitudinal adjustments. The horsehead can be positioned precisely over the center of the well. Wireline retaining brackets come standard on all pumping units.

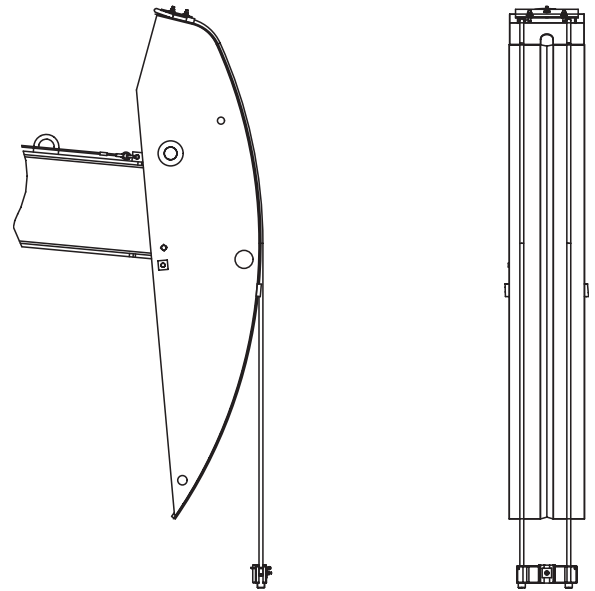

Jackshaft Assembly

The purpose of a jackshaft assembly is to enable the operator to slow down a pumping unit below its capabilities with standard sheaves and belts. Jackshafts are available with either a 2 1/4- or 2 7/8-in. single-shaft extension manufactured from 4140 annealed steel. The shaft is mounted on roller bearings and is housed and sealed to prevent contamination. An oil bath system supplies lubrication.

Jackshaft assemblies come complete with a universal-type mounting system, which allows an operator to retrofit the mounting system onto any type of pumping unit or directly onto the concrete base. The jackshaft is designed to carry sheaves that are up to 24 inches in diameter, which allows up to a 4 to 1 reduction, if necessary.

Another feature of this assembly is its swivel design, which allows for quick and uniform belt tensioning. This system permits the operator to release two bolts on the jackshaft, which allows the head to swivel back and forth. Both sets of belts can then be adjusted by moving the prime mover. When both sets of belts are at the desired tension, just retighten the swivel bolts to maintain belt tension.

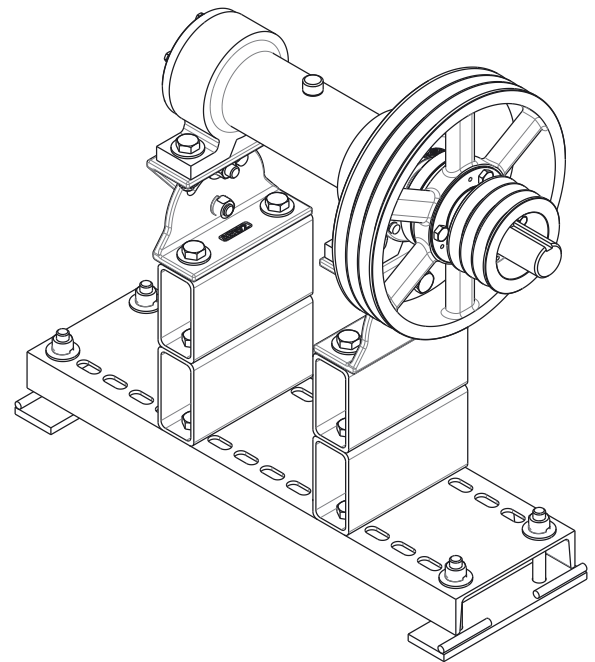

Effective Counterbalance Chart

Maximizer and Maximizer II Pumping Units

Maximizer Crank No.	CBTC* (2 cranks; in.-lb)	Maximizer II Crank No.	CBTC* (2 cranks; in.-lb)	Maximizer and Maximizer II Counter Weights	Weight (lb)	G (in.)
KB-117-53	551200	P9-117-49	471447	A	250	10.625
KC-117-53	689619	P14-117-49	506647	B	400	10.625
KB-99-43	405060	P15-117-54	506647	D	550	11.813
KB-76-36	174240	P15-99-39	390000	F	715	14.000
KLB-117-53	363107	P15-99-40	390000	H	870	15.750
KLB-99-43	243059	P15-122-54	761970	J	1060	16.750
KLB-76-36	72899	P13-122-55	773357	L	1225	18.000
KLB-64-36	72900			N	1560	20.500
KC-117-59	709464			P	1720	21.000
				R	2050	
				S	2545	20.938
				X	3470	24.750
				PJ	1531	11.831
				RJ	1890	13.451
				XJ	3182	18.795
				YJ	4755	23.273
				ZJ	6336	26.125
				1ZJ	7590	29.842

*CBTC of two cranks with wrist pins

Maximizer III Pumping Units

Crank No.	CBTC (2 cranks; in. - lb)	Counter Weights	W (lb)	G (in.)
A55L	62300	B	410	10.6
A80L	120600	D	540	11
A80	151000	F	720	14
A100	265200	H	870	15.2
A118, Group 4	492700	J	1045	16.8
A118, Group 5	495200	L	1240	17.7
A118, Group 6	495200	N	1535	19.7
		P	1875	21.7
		R	2040	21.3
		S	2850	20.8
		X	3375	23.8
		Y	4265	26.6
		Z	5230	28.8

- CBTC = Counterbalance torque of cranks (in.-lb)
- CBTW = Counterbalance torque of counterweights (in.-lb)
- ECB = Effective counterbalance at polish rod (lb)
- W = Total weight of counterweights used on two cranks (lb)
- X = Distance of counterweights from the end of crank (in.)
- G = Distance of center of gravity from counterweight bottom (in.)
- TF = Torque factor at 90°, from catalog (in.)
- SU = Structural imbalance at polish rod, from catalog (lb)
- CG = Center of gravity

$$CBTW = [(Crank No.) - (X + G)] \times W$$

$$ECB = \frac{CBTC + CBTW}{TF} + SU^*$$

Where SU* is found in this catalog, and the value is added or subtracted depending on sign.

To determine X:

$$A = [(Crank No.) - G]$$

$$B = (ECB - SU)$$

$$C = (B \times TF)$$

$$D = \frac{(C - CBTC)}{W}$$

$$X = A - D$$

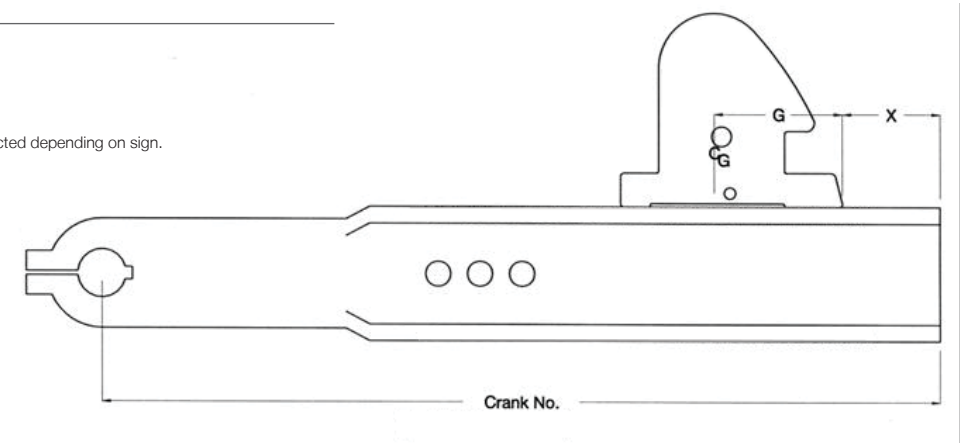

Useful Formulas

Strokes Per Minute (SPM)

Example:

d	= 12	pitch diameter of prime mover sheave
D	= 36	pitch diameter of gear reducer sheave
RPM	= 1170	revolutions per minute of prime mover
Ratio	= 30.03	ratio for 320 reducer

$$SPM = \left(\frac{RPM}{ratio}\right) \times \left(\frac{d}{D}\right) = \left(\frac{1170}{30.03}\right) \times \left(\frac{12}{36}\right) = 13$$

(rounded from 12.987)

Prime Mover Sheave Diameter (d)

Example:

SPM	= 13	strokes per minute
D	= 36	pitch diameter of gear reducer sheave
RPM	= 1170	revolutions per minute of prime mover
Ratio	= 30.03	ratio for 320 reducer

$$d = \left(\frac{SPM \times ratio \times D}{RPM}\right) = \left(\frac{13 \times 30.03 \times 36}{1170}\right) = 12$$

(rounded from 12.012)

Belt Velocity (v)

Example:

d	= 12	pitch diameter of prime mover sheave
π	= 3.142	
RPM	= 1170	revolutions per minute of prime mover

$$v = \frac{(\pi \times d \times RPM)}{12} = \frac{3.142 \times 12 \times 1170}{12} = 3676 \frac{ft}{min} \text{ or } FPM$$

Note: Limit between 2,000 and 5,000 ft/min (FPM).

Belt velocity less than 2,000 FPM results in poor belt life.
Belt velocity greater than 5,000 FPM requires dynamically balanced sheaves.

Belt Length

Example:

d	= 14.5 in.	pitch diameter of prime mover sheave
D	= 47 in.	pitch diameter of gear reducer sheave
CD	= 65.43 in.	distance from center of high speed pinion to center of prime mover shaft extension

$$BL = 2 \times CD + [1.57(D + d)] = 2 \times 65.43 + [1.57(47 + 14.5)] = 227.42"$$

Use C225 belts based on sheaves selected.

Horsepower of Prime Mover

Example:

BPD	= 217	barrels per day at 100% pump efficiency
Depth	= 5600 ft	pump setting
		Assume high-slip (NEMA D) motor

For high-slip electric motors and slow-speed engines

$$HP = \frac{BPD \times Depth}{56000} = \frac{217 \times 5600}{56000} = 21.7$$

For normal-slip electric motors and multi-cylinder engines
(use 25 HP motor)

$$HP = \frac{BPD \times Depth}{45000}$$

Strokes Per Minute Using a Jackshaft

Example:

RPM	= 1170	revolutions per minute of prime mover
R	= 30.03	ratio for 320 gear reducer
D	= 36 in.	pitch diameter of gear reducer sheave
d	= 12 in.	pitch diameter of prime mover sheave
J1	= 8 in.	jackshaft sheave diameter driving gear reducer sheave
J2	= 24 in.	jackshaft sheave diameter driving gear reducer sheave

$$PM = \frac{RPM}{R} \div \left[\frac{D}{J_1} \times \frac{J_2}{d}\right] = \frac{1170}{30.03} \div \left[\frac{36}{8} \times \frac{24}{12}\right] = 4.3$$

Branch Plants

Asia Pacific/Australia

Australia

Level 12, 133 Mary Street
Brisbane, QLD 4000
Tel: 61-7-3214-3000
Fax: 61-7-3214-3001

Thailand

399 Interchange Building,
Sukhumvit Rd
Wattana 10110 Thailand
Tel: 66-2674-5800
Fax: 66-2674-5804-5

Europe

Kazakhstan

Prizerniy Village
Pionerskaya 5
Kazakhstan 130000
Tel: 7-7292-203-450
Fax: 7-7292-203-464

Kazakhstan

Prizerniy Village
Pionerskaya 5
Aktau 130000
Tel: 7-7292-203-450
Fax: 7-7292-203-464

Thailand

399 Sukhumvit Road
Interchange Building, 31st
Floor
Klongtoey-Nua, Wattana
Bangkok, 10110 Thailand
Tel.: 66-2674-5800
Fax: 66-2674-5804/5

Australia

Unit 2, 209 Leitchs Road
Brendale, Australia 4500
Tel: 61.7.3482 9900
Fax: 61.7.3889 6261

Mexico

Tabasco

Av. Antimonio S/N Bodega
No. 12 Cd. Industrial
Villahermosa, Tabasco
86010
Tel: 52-993-358190
Fax: 52-993-1407377

Veracruz

Puebla/Veracruz
Carr. Pachuca-
Tuxpan Km 175+440
Venustiano Carranza, Puebla
Tel: 52-782-6-40-00
Fax: 52-746-881-21-09

Canada

Alberta

5520 50 Avenue
Bonnyville, AB T9N 2K8
Tel: 780-826-7318
Fax: 780-826-4310

6217 52 Avenue
Drayton Valley,
AB T7A 1R3
Tel: 780-542-7325
Fax: 780-542-4773

PO Box 21099
Grande Prairie,
AB T8V 6W7
Tel: 780-766-3000
Fax: 780-766-3030

4602 62 Avenue
Lloydminster,
AB T9V 2G2
Tel: 780-875-6123
Fax: 780-875-6526

1607 8th St
Nisku, AB T9E 7S7
Tel: 780-955-2646
Fax: 780-955-2632

6749 Weberville Road
Peace River,
AB T8S 1S3
Tel: 780-624-0719
Fax: 780-624-0658

Manitoba

NW 5-4-26W1
Melita, MB R0M 1L0
Tel: 204-522-8455
Fax: 204-522-8452

MENA

Bahrain

Weatherford Drilling
International Bahrain W.I.L
House 64,
Government House 1128,
Road 4528, Block 945
Awali Compound, Bapco,
Kingdom of Bahrain
P.O. Box 25075
Tel: 973-1-7003818
Fax: 973-1-7004517

Egypt

Industrial Zone 5,
Zahraa El Maadi
PO Box 903, Egypt
Tel: 20-2-242-22600
Fax: 20-2-242-18410

Kuwait

Weatherford Kuwait for
Petroleum Services
Mina Abdullah,
Next to PWC Logistic Center,
Yard No: 6 & 8
Kuwait, Postal Code:
PO Box 26258
Safat 13123 Kuwait
Tel: 965-2227-3400
Fax: 965-2225-0232

Oman

Head Office,
P.O. Box 1538
Postal Code 130,
Building No: 515/1,
Way No. 246

18th November Street,
Azaiba, Oman
Tel: 968-24124000
Fax: 968-24124200

Tunisia

Weatherford Oil Tools GMBH
Route de Gabes
Km 2.5, Sfax
Tunisia 3003 SFAX 3003
Tel: 21693222354
Fax: 21674469600

United States

California

21728 Rosedale Hwy
Bakersfield, CA 93314
Tel: 661-654-8813
Fax: 661-587-2456

Colorado

4005 N Valley Dr.
Longmont, CO 80504
Tel: 970-535-4021
Fax: 970-535-4865

3801 Freedom Rd
Trinidad, CO 81082
Tel: 719-845-0015
Fax: 719-845-0016

New Mexico

2801 South 1st Street
Artesia, NM 88210
Tel: 575-393-3191
Fax: 575-393-4892

3220 Bloomfield Hwy
Farmington, NM 87401
Tel: 505-564-8381
Fax: 505-564-8194

2617 W. Marland
Hobbs, NM 88241
Tel: 575-393-3191
Fax: 575-393-4892

North Dakota

2708 5th Ave, West
Dickinson, ND 58601
Tel: 701-227-8768
Fax: 701-227-8769

105 34th Ave NE
Minot, ND 58701
Tel: 701-839-0736
Fax: 701-839-0762

4991 133rd Dr NW
611 37th Ave. SE,
Williston, ND 58801,
Tel: 701-774-1030

Oklahoma

Hwy 81 South Box 666
Hennessey, OK 73742
Tel: 405-853-7181
Fax: 405-853-2645

1900 S.E. 25th St.
Oklahoma City, OK 73129
Tel: 405-672-0003
Fax: 405-677-5091

Texas

188 SE CR 1000
Andrews, TX 79714
Tel: 432-524-5003
Fax: 432-525-6360

8401 Hwy 83 N
Aspermont, TX 79502
Tel: 940-989-3545
Fax: 940-989-2216

Texas CONTINUED

820 Industrial Blvd
Bryan, TX 77803
Tel: 979-778-5385
Fax: 979-822-5680

311 East Broadway
Coahoma, TX 79511
Tel: 432-394-4289
Fax: 432-394-4989

Hwy 214 N
Denver City, TX 79323
Tel: 806-592-4825
Fax: 806-592-7961

159 West Hwy 302
Kermit, TX 79745
Tel: 432-586-3883
Fax: 432-586-3885

219 Industrial Dr
Longview, TX 75602
Tel: 903-353-9700
Fax: 903-234-1076

2261 Wolfcamp Circle
Midland, TX 79706
Tel: 432-697-1868
Fax: 432-697-8868

8866 NW Loop 338
Odessa, TX 79764
Tel: 432-368-3800
Fax: 432-368-0954

NW Loop 143 Box 966
Perryton, TX 79070
Tel: 806-435-6801
Fax: 806-435-6803

19685 IH 37 South
San Antonio, TX 78112
Tel: 210-306-3643
Fax: 210-621-9216

302 N. Slaughter Ave.
Sundown, TX 79372
Tel: 806-592-4825
Fax: 806-592-7961

Utah

1557 South 2000 West
Roosevelt, UT 84066
Tel: 435-722-4092
Fax: 435-722-2087

Wyoming

3307 East 2nd Street
Gillette, WY 82718
Tel: 307-682-8056
Fax: 307-682-1513

Repair Centers

Argentina

Villa Mercedes
Ruta Nac N7,
km 702.5
San Luis 5730
Tel: 54-2657-433133
Fax: 54-265-7433561

Colombia

Santander
Km. 8 vía Barrancabermeja
- Distrito de producción El
Centro
Barrancabermeja, Santander
Tel: 57-7-6-10-50-00

Venezuela

Zulia
Sector Barrio Libertad
Carretera K
Ciudad Ojeda, Zulia
Tel: 58-265-4004605

Anzoategui
Carretera Nacional Vía
Ciudad Bolívar
Km.1 margen izquierdo
El Tigre, Anzoategui
Tel: 58-283-2310555

Peru

Barrio Plomo S/N
El Alto
Talara, Piura
Tel: 51-73-256088

Ecuador

Vía Lago Agrio Km 12
El Coca, Ecuador

Trinidad

West Indies

LP 7 Guayamare Link Road,
Uriah Butler Highway
Charlottesville, Cunupia
Tel: 1-868-665-7152

Oman

Nimr
Head Office
P. O. Box 1538,
Postal Code 130
Building No: 505/1,
Way No. 246
18th November Street,
Azaiba
Tel: 968-24124000
Fax: 968-24124200

United States

California
21728 Rosedale Hwy
Bakersfield, CA 93312
Tel: 661-654-8120
Fax: 661-587-2456

North Dakota
4991 133rd Dr NW
611 37th Ave. SE,
Williston, ND 58801,
Tel: 701-774-1030

Oklahoma
2836 SE 15th
Oklahoma City,
OK 73129
Tel: 405-677-2410
Fax: 405-677-2041

Texas
820 Industrial Blvd.
Bryan, TX 77803
Tel: 979-778-5913
Fax: 979-822-5680

2261 Wolfcamp Circle
Midland, TX 79706
Tel: 432-697-1868
Fax: 432-697-8868

8866 NW Loop 338
Odessa, TX 79764
Tel: 432-368-3801
Fax: 432-368-3803

NW Loop 143, Box 966
Perryton, TX 79070
Tel: 806-435-6801
Fax: 806-435-6803

19685 IH 37 South
San Antonio, TX 78112
Tel: 210-306-3643
Fax: 218-621-9216

Global Pumping Unit Parts Center

United States

11510 W Hwy 80 E
Odessa, TX 79765
Tel: 432-563-0598
Fax: 432-561-8590

Terms And Conditions Of Sale

Weatherford sells its Maximizer[®] line of surface pumping units (“Maximizer[®] Units”) subject to and in accordance with the terms and conditions of the most current applicable master services, supply, rental or other agreement between Weatherford and the customer (“Master Agreement”) covering the Maximizer[®] Units, if any.

If no Master Agreement exists or applies to the Maximizer[®] Units, those units will be sold and provided subject to and in accordance with Weatherford’s standard terms and conditions of sale, service and rental, which can be viewed and printed at www.weatherford.com/t&c (“Terms and Conditions”).

Those terms and conditions include disclaimers of warranties and limitations on remedies and contain release and indemnity provisions which absolve weatherford from the consequences of its own fault or negligence, including, in some circumstances, its own gross negligence.

The customer should read them carefully before ordering Weatherford Maximizer[®] Units. Weatherford may revise and post updates to the terms and conditions from time-to-time, and sales of Maximizer[®] Units will be subject to the most recently posted version of the terms and conditions.

Weatherford Product Warranties

In lieu of the general Weatherford Product Warranties described in the Terms and Conditions, Weatherford provides the following specific, limited warranties and remedies with respect to Weatherford Maximizer[®] Units and the components thereof. Weatherford warrants to the original purchaser of the Maximizer[®] Unit that the Maximizer[®] Unit will be and remain free of defects in material and workmanship for a period of five (5) years from the date the Maximizer[®] Unit is delivered. With respect to the parts and components of the Maximizer[®] Units that are subject to wear under normal operating conditions (such as contact type oil or grease seals, hoses, belts, elastomeric parts, wireline, brake rod and brake pad assemblies) Weatherford warrants to the original purchaser of the Maximizer[®] Unit that such parts and components will be and

remain free of defects in material and workmanship for a period of one (1) year from the date the Maximizer[®] Unit was delivered. The foregoing warranty does not apply to (i) parts or components of the Maximizer[®] Unit not manufactured by Weatherford, such parts and components being subject to any applicable manufacturer’s warranty; or (ii) parts or components not listed above requiring replacement because of normal wear and tear.

The foregoing warranties are the sole and exclusive warranties made by Weatherford with respect to Weatherford Maximizer[®] Units, and **Weatherford hereby expressly disclaims any and all other warranties, expressed or implied, including the implied warranties of merchantability or fitness for use or purpose.**

The foregoing warranties do not apply to (i) Maximizer[®] Units that have been modified

by the customer or any third party after their delivery; (ii) Maximizer[®] Units subjected to improper handling or storage; (iii) Maximizer[®] Units that have not been installed, operated, and maintained by the customer in accordance with the operating guidelines and manuals furnished by Weatherford (the “Operating Guidelines”), including the use of replacement parts not authorized in the Operating Guidelines; (iv) Maximizer[®] Units which were modified by Weatherford according to specifications furnished by the customer; or (v) Maximizer[®] Units with respect to which the customer fails to implement any adjustment to (or replace any component of) the Maximizer[®] Unit recommended by Weatherford and furnished by it without cost to the customer.

With respect to Maximizer[®] Units specifically configured or equipped for the customer using SROD[™], RODSTAR, or other third party predictive/modeling software tools (“Software Tools”) using well data or values supplied by the customer, Weatherford makes no warranty whatsoever as to the accuracy of the predictive system loading conditions generated by those Software Tools or warrant in any way the performance of Maximizer[®] Units thus configured or equipped which are not operated in accordance with the Operating Guidelines. **Actual Maximizer[®] Unit operating data (measured loads and speeds), to which Weatherford must be given access, and not the predicted performance generated by the Software Tools, will be used to determine whether the Maximizer[®] Unit has been operated in accordance with the Operating Guidelines.**

Customer’s Remedies

Weatherford shall, at its sole cost and expense, and at its option, either repair or replace (FCA the Weatherford plant from which the Maximizer[®] Unit was originally shipped or a designated repair facility) any Maximizer[®] Unit (or any Unit component) not conforming to the warranties set forth above; provided (i) the customer has notified Weatherford of the non-conformity within the applicable warranty period and within thirty

(30) days of discovering the non-conformity, (ii) preserves and furnished to Weatherford for analysis all affected components of the Maximizer[®] Unit, and (iii) provides Weatherford with access to all well operating data for the well on which the Unit was installed, which shall be used to determine whether the Unit was at all times operated in accordance with the Operating Guidelines.

The foregoing remedies of repair or replacement shall be the sole and exclusive obligations and responsibilities of Weatherford (and the sole and exclusive remedies of the customer) with respect to any Maximizer[®] Unit not conforming to the warranties specified above. Weatherford’s responsibility to repair or replace the Maximizer[®] Unit shall not exceed the price of the original Maximizer[®] Unit

or extend to any ancillary or related costs (including shipping, installation, removal, mobilization or demobilization) not included in the original order under which the Maximizer[®] Unit was purchased. A new warranty period shall not be established for repaired or replaced Maximizer[®] Units or parts. Such items shall remain under warranty only for the remainder of the original warranty period.

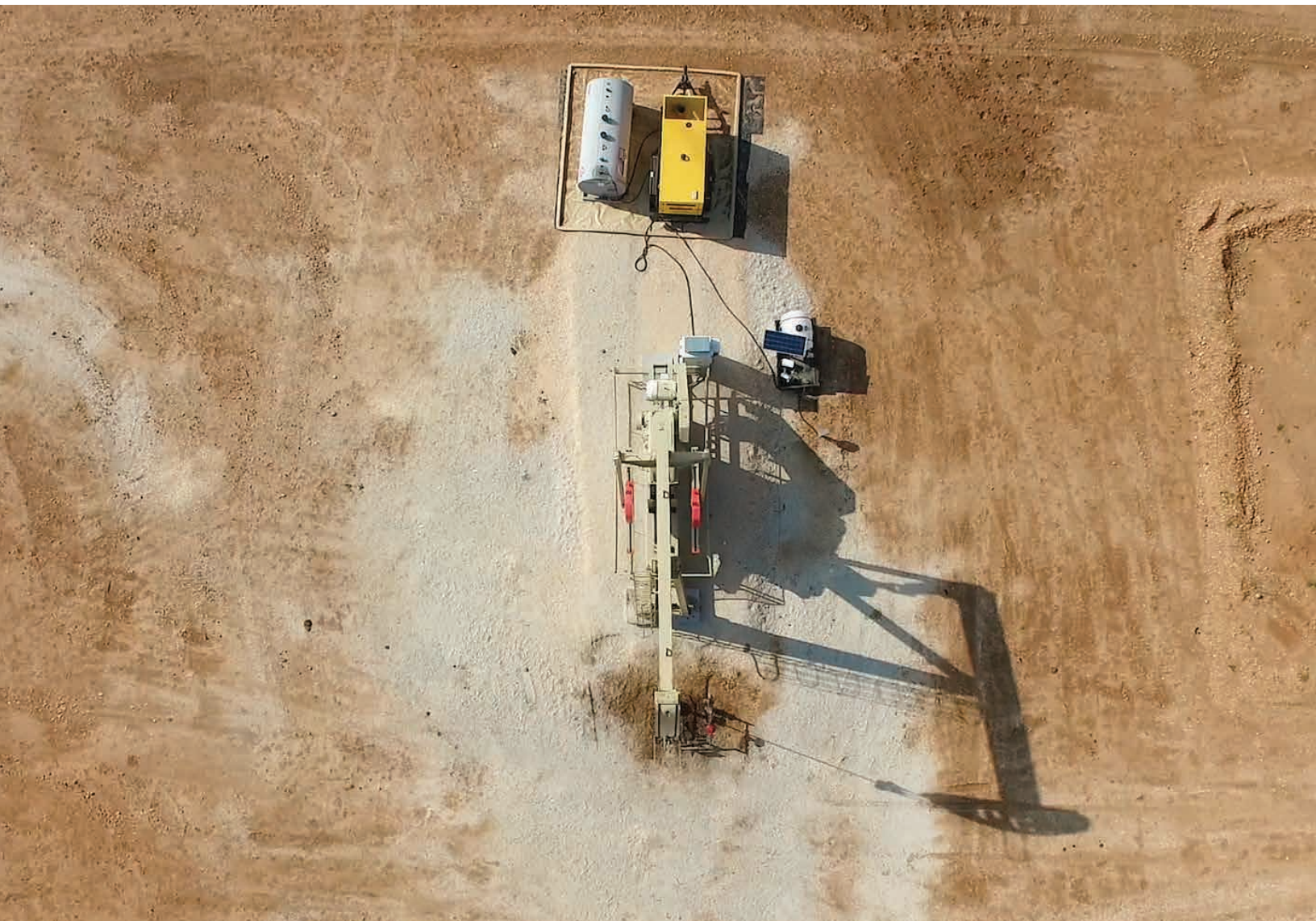



STRONGEST OFFERING AND EXPERIENCE ONLY FROM WEATHERFORD

Weatherford provides worldwide service and support from approximately 600 locations in more than 100 countries. To learn more about how our surface pumping units can help you expedite projects and lower operating costs, contact an authorized Weatherford representative or visit weatherford.com.

CONNECT WITH WEATHERFORD



©2014 - 2018 Weatherford. All rights reserved. 11219.02

Weatherford products and services are subject to the Company's standard terms and conditions, available on request or at weatherford.com. For more information contact an authorized Weatherford representative. Unless noted otherwise, trademarks and service marks herein are the property of Weatherford and may be registered in the United States and/or other countries. Weatherford products named herein may be protected by one or more U.S. and/or foreign patents. Specifications are subject to change without notice. Weatherford sells its products and services in accordance with the terms and conditions set forth in the applicable contract between Weatherford and the client.

Maximizer is a registered trademark of Weatherford in the US, Argentina, Canada, Mexico, Oman, and Venezuela.

StrapJack is a registered trademark of Weatherford in the US. Maximizer is a registered trademark of Weatherford in the US, Argentina, Canada, Mexico, Oman, and Venezuela.